

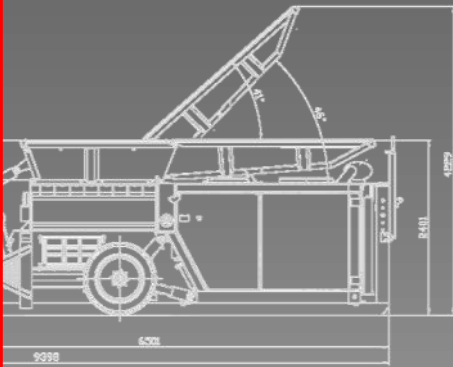

HAMMEL[®]
RECYCLINGTECHNIK

Primary Shredder

VB 650 D # 935



construction year: 06 / 2015
operation hours: approx. 600 h
drive: diesel QSB 6.7 C260
power: approx. 273 PS

shafts: regenerated
weight: approx. 18,5 t
colour: RAL 3020 red
warranty: until 12 / 2016 or
up to max. 2.000 h



version: hook-lift frame
wheel axle
breaker bar

phone: 338.6625143 Nord Italia
328.7269648 Centro/Sud

e-mail: info@4service.it



Extra equipment at additional charge.
Information subject to change.
Should you have further questions, please
do not hesitate to contact us.

status Feb. 2016